

Gears & Levers

Assembly Instructions

This elegant apparatus provides a thorough introduction to angles, ratios, rotation, torque, and simple machines. The 19-piece set features durable metal bearings and includes hardware, levers, and four gears with printed angle markings. Multiple sets can be combined to build more complex machines. To make the equipment a more effective learning tool, a detailed *Curriculum Resource Guide* is available which includes a set of multi-level, classroom-ready student Activity Guides. The Activity Guides are suitable for portfolio assessment, and provide structured student explorations that integrate math and science concepts. *Follow these instructions to set up your Gears & Levers.*

Parts Checklist

The following items are provided with the Gears & Levers:

- Gears (4)
- Levers (2)
- Short thumbscrew (3)
- Long thumbscrew (3)
- Knob (5)
- Aluminum Spacer (2)
- String loops (4)

Attaching the Physics Stand

The Gears attach to the Physics Stand with thumbscrews and knobs. There are two sizes of thumbscrews, use the shortest ones for single gears and the longer ones to double gears (or levers) up.

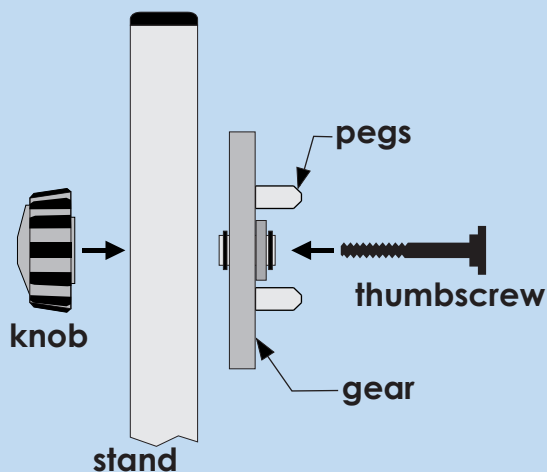

Angles are marked in both degrees and radians. The pitch circle marks the diameter at the point of contact between meshed gears.

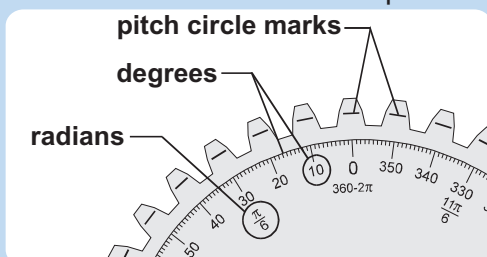

Setting up the Gears

Use the pole as a reference point to show the angle for each gear as they are turned.

The angle markings allow math concepts such as ratios, degrees, and circles to be taught in a hands-on manner.

NOTE: KEEP FINGERS AND OTHER OBJECTS OUT OF THE REGION WHERE GEARS MESH.

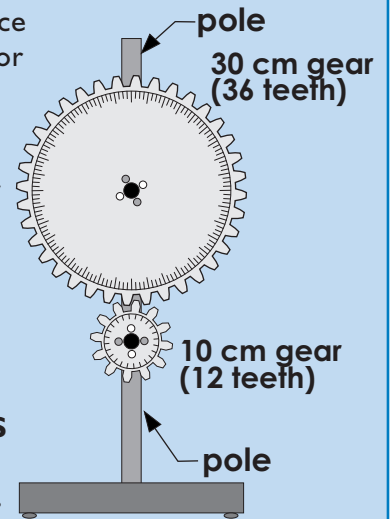

Attaching Levers

The Levers can be attached to the gears to demonstrate that the torque transmitted through a gear train is inversely related to the gear ratio.

Also, by combining Gears from two or more sets, students can build machines with mechanical advantages of up to 18 to 1.

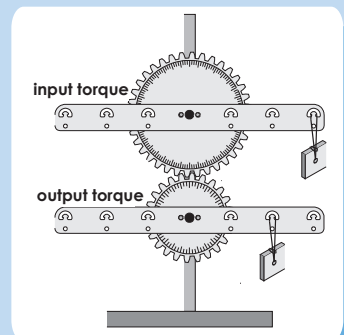

Stacking two gears or a gear and lever.

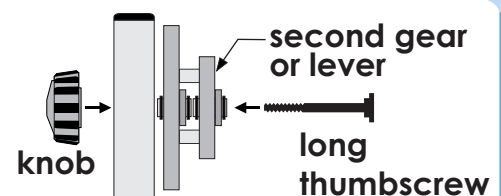

For technical assistance, please call 866.588.6951.