

Ropes and Pulleys

Assembly Instructions

The Ropes & Pulleys set is an ideal tool for teaching students the concepts of simple machines, force, work and energy. The unique construction of this apparatus helps prevent tangled strings and features low-friction ball bearing pulleys for accurate force measurements. Simple block and tackle machines with mechanical advantage from 1 to 6 are easy to construct.

Parts Checklist

The following items are provided with the Ropes & Pulleys:

- top pulley block
- bottom pulley block
- 6.5 m of yellow string with lanyard clip and 2 cord locks
- blue knob with attached threaded rod
- black knob

In addition, you will need these items:

- Physics Stand, assembled
- weights, set of eight
- spring scales
- tape measure

Attaching the Physics Stand

Slide the threaded rod that is attached to the top pulley block through a hole near the top of the Physics Stand. Secure the top pulley block with the black plastic knob. You should now have the top pulley block secure while the bottom pulley block hangs below on the two red safety strings.

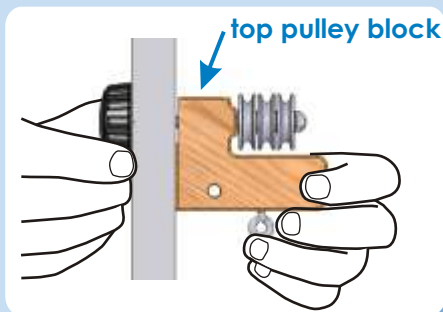

Attaching Weights

Add weight to the bottom pulley block by removing the blue knob from the bottom of the pulley and adding weights to the threaded rod. Then screw the knob back into the pulley.

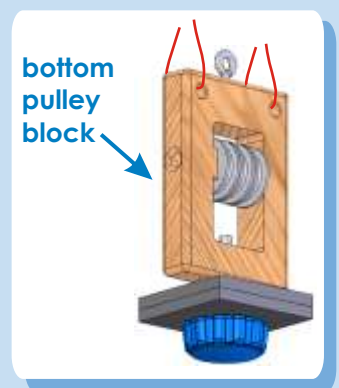

Positioning the String

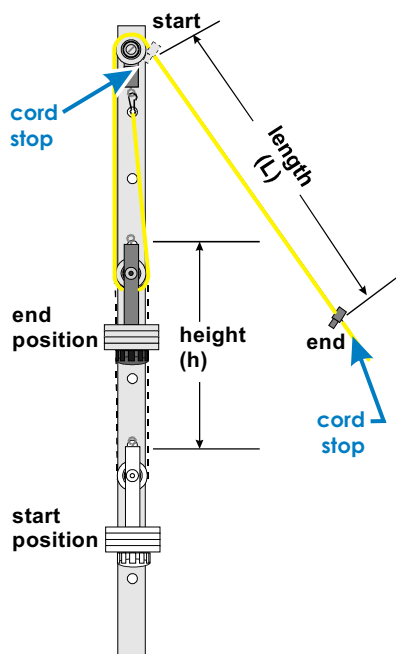

The yellow string is the cable you will use to move the bottom pulley block (with the weights) up and down. The two cord stops are for measuring the length of string needed to raise the lower block a given distance.

The yellow string may have several strands that support the bottom pulley block. These are called **supporting strands**. By winding around the top and bottom pulleys, you can have from 1 to 6 supporting strands.

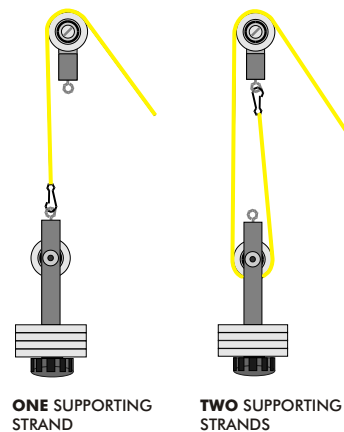

The yellow string can be clipped to either the top **or** bottom pulley block. When using an odd number of supporting strands, have the string clipped to the bottom pulley block. When using an even number of supporting strands,

have the string clipped to the top pulley block.

Thread the yellow string over one or more of the pulleys of the top and bottom pulley blocks.

For technical assistance, please call 866.588.6951.